



ELSEVIER

Journal of Chromatography A, 710 (1995) 3–19

JOURNAL OF
CHROMATOGRAPHY A

Review

Trace enrichment methods for the determination of organic pollutants in ambient air

V. Camel^a, M. Caude^{b,*}

^aLaboratoire de Chimie Analytique, Institut National Agronomique Paris–Grignon, 16 rue Claude Bernard, 75231 Paris Cedex 05, France

^bLaboratoire de Chimie Analytique (associé au CNRS No. 437), Ecole Supérieure de Physique et Chimie Industrielles de Paris, 10 rue Vauquelin, 75231 Paris Cedex 05, France

Abstract

The sampling and analysis of organic compounds in air remain a challenge. Air is a matrix very difficult to handle. In addition, the pollutants are usually present at very low concentrations; so, their detection and quantitation require a preconcentration step. This paper describes the enrichment methods that may be used for the accurate monitoring of pollutants in ambient air.

Many techniques can be used to collect air samples. The simplest way is to use special containers, but this procedure is expensive and time-consuming. The adsorption of pollutants on adsorbents faces a growing interest, despite the difficulty to choose the appropriate support in order to obtain quantitative yields. To overcome this problem, two or three types of adsorbents may be used in series for collecting a wide range of analytes. In addition, the miniaturization of these techniques (i.e. microtraps and solid-phase microextraction) is also very promising: easy to handle, low cost, no solvent required, detection limits at the ppt level when sensitive detectors are used.

Contents

1. Introduction	4
2. Whole-air sampling	4
2.1. Plastic bags	4
2.2. Glass or stainless-steel containers	5
3. Collection in a solvent or on impregnated surfaces	5
3.1. Collection in a solvent	5
3.2. Collection on impregnated surfaces	6
4. Cryotrapping	6
5. Collection onto adsorbents	7
5.1. Nature of the adsorbents	7
5.1.1. Activated carbon, graphitized carbon blacks and carbon molecular sieves	7
5.1.1.1. Activated carbon	7
5.1.1.2. Graphitized carbon blacks	8

* Corresponding author.

5.1.1.3. Carbon molecular sieves	9
5.1.2. Porous polymers	9
5.1.2.1. Tenax	9
5.1.2.2. Chromosorb series	11
5.1.2.3. Porapak series	11
5.1.2.4. HayeSep series	11
5.1.2.5. Amberlite XAD resins	11
5.1.2.6. Polyurethane foam	11
5.2. Sampling mode	11
5.2.1. Passive sampling (or diffusive sampling)	11
5.2.2. Active sampling	12
5.3. Desorption mode	14
5.3.1. Thermal desorption	14
5.3.2. Liquid extraction	14
5.4. Microtraps	15
6. Collection onto filters	15
6.1. Glass-fibre filters (or quartz-fibre filters)	15
6.2. PTFE filters	16
6.3. Coated filters	16
7. Collection onto fibers	17
7.1. Solid-phase microextraction	17
7.2. Membrane extraction with a sorbent interface	17
8. Conclusions	18
References	18

1. Introduction

For several years, there has been a growing interest in the protection of our atmosphere. As a consequence, air pollution needs to be strictly and carefully controlled. This requires accurate analytical procedures.

As a matter of fact, air is probably the most difficult environmental matrix to sample. It is a heterogeneous system of gases, liquids (aerosols) and solid particles. Besides, its composition continuously evolves. Pollutants not only diffuse and move, but they also chemically react in the atmosphere; this eventually can lead to secondary pollutants much more toxic than the initially emitted compounds. Consequently, air pollution is very difficult to control.

A monitoring device of air pollution should fulfil at least three conditions: (1) the air sampled needs to be representative; (2) the procedure should be very simple to be performed in any region (even when no electric power supply is available); (3) no degradation or losses between sampling and analysis may occur.

Also, due to the low concentrations of pollutants in the atmosphere, an enrichment step is

often required in order to reach acceptable detection limits.

2. Whole-air sampling

The simplest way to collect air samples is to use special containers. The samples are later analysed by gas chromatography (GC), either by direct injection, or in combination with a pre-concentration step. The latter method offers a better sensitivity, which is very useful when dealing with trace components.

The most widely used sampling vessels are plastic bags and glass or stainless-steel containers.

2.1. Plastic bags

Polymer bags (usually Teflon, Tedlar or aluminised Tedlar) are very simple to use and can allow 10 to 100 l of air to be sampled. However, filling the bags requires the air sample to be pumped in, which may add a potential source of contamination.

2.2. Glass or stainless-steel containers

A simple glass container can be used for sampling air. As an example, a 1-l glass bottle sealed with a poly(tetrafluoroethylene) (PTFE) plug equipped with a PTFE stopcock was used for sample collection of car exhausts (prior to sampling, air within the bottle was evacuated with a vacuum pump) [1]. Trace volatile aldehydes were further determined by GC, after their derivatization to thiazolidine derivatives [1].

Stainless-steel containers have also been frequently used. These recipients (called “canisters”) entail less contamination problems than polymer bags, but they are more expensive. Prior to their use, the canisters have to be carefully pretreated and conditioned, in order to avoid contamination or surface losses. Besides, minimising of the active surface area is also essential [2]; this can be achieved by electropolishing.

The volume of containers is limited to a few litres, unless the samples are pressurised to allow larger amounts of air to be collected [3].

A passivated canister is an ideal container for volatile and apolar species. Accurate representation of the air under investigation can be obtained, provided it can be effectively cleaned. For example, the United States Environmental Protection Agency canister method TO-14 coupled with gas chromatography–mass spectrometry (GC–MS) analysis, allowed the monitoring of volatile organic compounds (VOCs) in urban air [4]. The samplers were operated in a passive mode (i.e. vacuum filling) to eliminate the pump as a potential source of contamination or air leaks.

These samplers offer several advantages that make them attractive in air analysis. The actual air sample is collected without any breakthrough; in addition, no degradation of the trapping materials takes place, and moisture has no effect upon the sampling. Finally, several analyses of the sample can be performed.

However, they present major drawbacks: they require complex sampling apparatus, severe clean-up procedures between samples, and they

are expensive to transport. In addition, to achieve acceptable sensitivity, air contained within canisters needs to be preconcentrated (using either a cold trap or a cryofocussing device) if trace components have to be monitored [5,6]. The trapped analytes are then thermally desorbed and transferred into the GC column, as illustrated in Fig. 1 [5]. In some particular cases, a second cryogenic system can be added, to provide narrower bands before the capillary column [3,7].

3. Collection in a solvent or on impregnated surfaces

3.1. Collection in a solvent

For solvation-based sampling, the sample is bubbled (using a pump) through a volume of solvent in a recipient (called an “impinger” or a “bubbler”) where the analyte is dissolved. To enhance the liquid transfer of the solutes, the air bubbles have to be as small as possible. For that reason, several types of bubblers have been designed [8,9]. To protect the pump against the solvent vapours inside the impinger, a trap filled with methanol–dry ice can be used [10,11].

This technique is very simple to perform and allows large volumes of air to be sampled. To avoid losses, the solvent needs to have a high boiling point. Besides, collection can be performed by using two bubblers in series. Using this system and further GC analysis, determination of trace amounts of epichlorohydrin in workplace atmospheres could be achieved with a high sensitivity ($0.05 \mu\text{g ml}^{-1}$) [12].

By adding a specific reactant to the collection solvent, chemisorption takes place. This proved to be effective for the direct detection of low-molecular-mass aldehydes in automobile exhaust gas [13]. In that example, 2,4-dinitrophenylhydrazine (2,4-DNPH) and an acidic catalyst were added to the solvent. Simultaneous sample collection and derivatization took place within the impinger. An aliquot of the solution was then injected into a liquid chromatograph (LC), without any extraction or concentration step; 2,4-

PRECONCENTRATION STEP

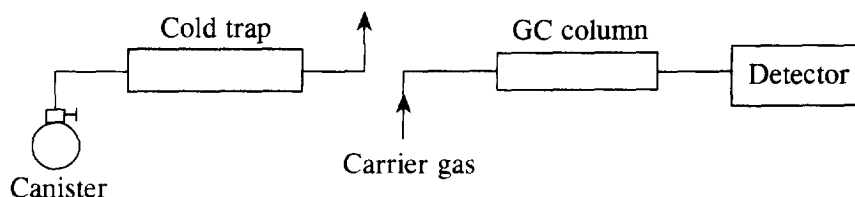

THERMAL DESORPTION

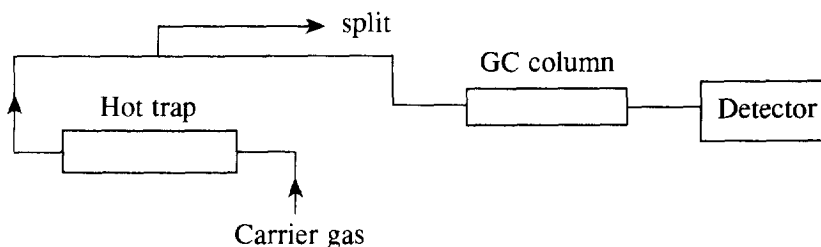

Fig. 1. Schematic representation of the transfer of canister-air samples to the gas chromatograph, using a preconcentration step and a thermal desorption. From Ref. [5].

DNPH and its derivatives were identified by ultraviolet (UV) and mass spectrometric detection.

3.2. Collection on impregnated surfaces

Glass tubes can be used to fix a sorptive agent (they are called "wet denuders") [14]. The inner wall of the tube has to be treated to maintain a compact film of liquid. Before sampling, the tube is placed vertically to assure correct operation. Then, a film of absorbing liquid flows continuously down the inner wall of the denuder, while gas passes counter-currently and, in this way, a continuous stream of concentrated analytes is obtained at the bottom of the tube. The concentrate can be analysed directly.

This system was employed for the monitoring of 2,4,5-trichlorophenol [14]. A 50-cm length tube, with water as the liquid, allowed a collection efficiency greater than 99% for an air flow-rate of 0.5 l min^{-1} . A similar system gave 40–

60% collection efficiencies (flow-rate of $0.6\text{--}0.7 \text{ l min}^{-1}$) for airborne cocaine and heroin [15].

Annular denuders have also been designed: they consist of an outer and an inner glass tube, held in coaxial position. Such a sampler, coated with 2,4-DNPH, was investigated for the collection of $C_1\text{--}C_3$ aldehydes in air and exhaust gas [16].

In practice, wet denuders offer a continuously renewed collection surface, a rapidly obtainable concentrate of solutes, and the possibility of direct analysis. They are especially useful in detecting and quantitating compounds that cannot be analysed by conventional preconcentration with GC (i.e. polar or highly reactive analytes).

4. Cryotrapping

Cryotrapping (or cryogenic concentration) is the technique of choice in several studies of air samples [17]. Most of the time, no adsorbents

are used in cryotrap, which allows desorption at moderate temperatures (40–70°C), thus avoiding interferences arising from solutes thermal degradation [18]. Addition of a second cryotrap, just at the entry of the chromatographic column, is necessary to give narrow chromatographic bands, compatible with a capillary analytical column.

A possible cryogenic trap consists of a U-shaped borosilicate glass tube immersed in liquid argon. The lower portion of the tube is packed with quartz wool to increase the contact surface. Ambient air samples are collected by connecting the trap to a portable pump. Air volumes of 1 to 10 l were drawn through the trap at flow-rates of 0.15–0.30 l min⁻¹. For instance, volatile sulphur compounds were preconcentrated with this system, then desorbed at 60–70°C, and finally cryofocussed in a second trap immersed in liquid argon, and injected in a GC [17]. Detection limits less than or equal to 10 pg of sulphur per litre of air were achieved for individual compounds.

Another reported trap consisted of a U-shaped stainless-steel tube packed with 60–80 mesh untreated glass beads [7]. Frits (1 μm) and silanized glass-wool were placed at both ends of the tube to keep the glass beads in place. Again, liquid argon (–186°C) was used to cool the trap. After sampling air, the tube was heated to 100°C and the sample was swept with helium in a cryofocussing device prior to the GC. With this system, urban measurements of hydrocarbons (C₂–C₁₀) could be made (concentrations ranging from several ppt to 100 ppb by volume in air samples). The resulting chromatogram is presented in Fig. 2 [7].

In practice, high water content in air causes a lot of problems when using cryotrapping. For example, plugging frequently occurs; also, when the trap is heated, water collected on the trap may be transferred to the GC column, which affects the analytes separation. They can be eliminated by placing a drying tube before the cryogenic trap to remove air humidity [6,18].

As a consequence, most of the time, cryotrapping serves as a cryofocussing mechanism, in

conjunction with solid adsorption–thermal desorption.

5. Collection onto adsorbents

Sampling on adsorbents allows larger volumes than with canisters to be collected [19]; besides, adsorbents are easier to handle than canisters.

This technique can be applied using two distinct modes: passive or active [2,8]. Whatever the mode, the concentrated analytes may be recovered with either thermal desorption or liquid extraction. Each method will be briefly discussed below, after which the main characteristics of common solid sorbents will be detailed.

Usually, a cryofocussing trap is needed before the GC analysis, to entail narrow bands entering the capillary columns, and thus good resolutions [20].

5.1. Nature of the adsorbents

Usually, porous polymers are the best choice. However, when a higher capacity is needed, activated carbon and graphitized carbon blacks should be used.

5.1.1. Activated carbon, graphitized carbon blacks and carbon molecular sieves

5.1.1.1. Activated carbon

Activated carbon is prepared by low-temperature oxidation of vegetable charcoal. This material has a large specific surface area (300–2000 m² g⁻¹), a high thermal stability (up to 700°C), and a heterogeneous surface containing active functional groups (including phenolic, carboxylic, quinone and lactone groups). It was firstly used to trap volatile organic compounds in ambient air [21]. Anyway, its use failed because of several problems encountered: adsorption of water, irreversible adsorption and/or degradation of the analytes, high desorption temperature required (the latter can be overcome by using solvent extraction instead of thermal desorption). When dealing with trace components,

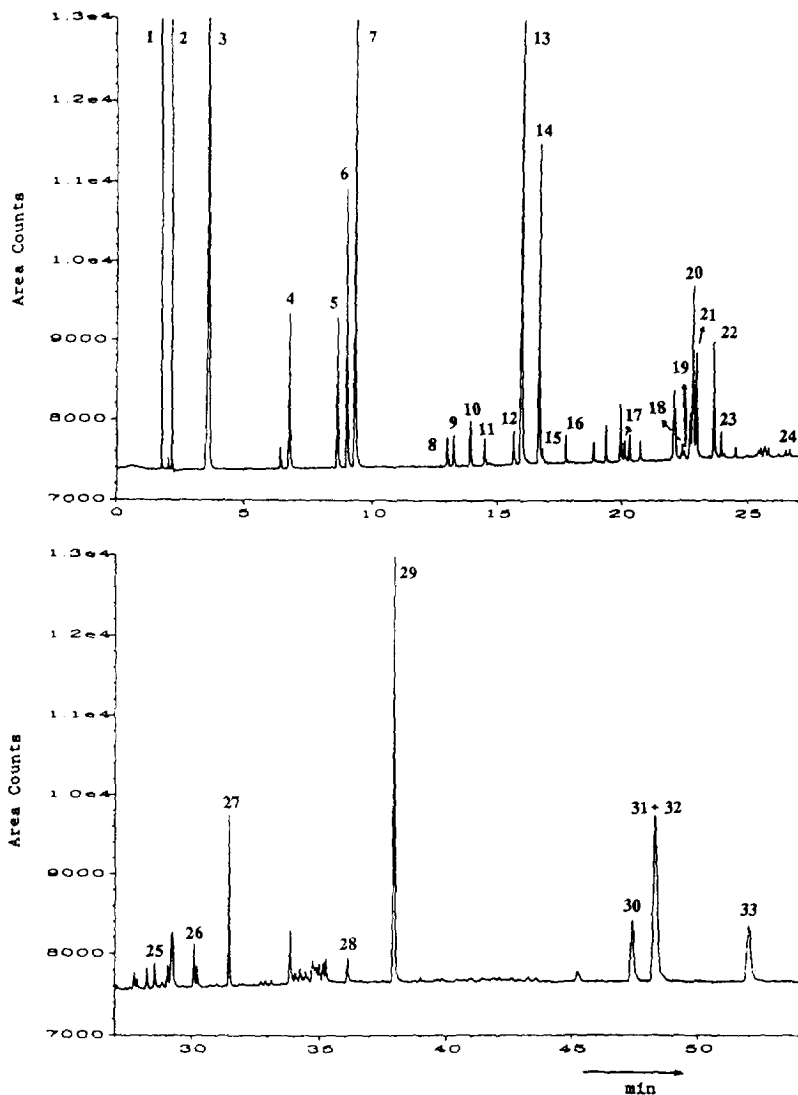

Fig. 2. Separation of urban air pollutants (sampling site Toronto, Bay street; sampling volume 640 ml). Peaks: 1 = ethane; 2 = ethylene; 3 = propane; 4 = propene; 5 = isobutane; 6 = acetylene; 7 = *n*-butane; 8 = *trans*-2-butene; 9 = 1-butene; 10 = isobutene; 11 = *cis*-2-butene; 12 = cyclopentane; 13 = isopentane; 14 = *n*-pentane; 15 = propyne; 16 = 1,3-butadiene; 17 = 1-pentene; 18 = cyclohexane; 19 = butyne; 20 = 2-methylpentane; 21 = 3-methylpentane; 22 = *n*-hexane; 23 = isoprene; 24 = 1-hexene; 25 = methylcyclohexane; 26 = *n*-heptane; 27 = benzene; 28 = *n*-octane; 29 = toluene; 30 = ethylbenzene; 31 = *m*-xylene; 32 = *p*-xylene; 33 = *o*-xylene. GC conditions: Al_2O_3 -KCl porous-layer open tubular (PLOT) column (50 m \times 0.32 mm I.D., 5- μm film thickness); temperature programme 35°C (2 min), increased at 5°C min⁻¹ to 200°C, 22 min isothermal; carrier gas (helium) linear velocity 56.84 cm s⁻¹. From Ref. [7].

these drawbacks are accentuated, leading to low recovery and artefacts.

To minimize these problems, graphitized carbon blacks may be used [22].

5.1.1.2. Graphitized carbon blacks

These are non-specific, non-porous adsorbents, with a high surface homogeneity and hydrophobic properties. Indeed, the graphitiza-

tion process eliminates the specific adsorption sites and hinders the formation of hydrogen bonds. As a consequence, very polar and small molecules (like water) are not strongly adsorbed. These materials differ in their surface area and the extent of graphitization: the larger the graphitization, the smaller the surface area, which ranges between 6 and 100 m² g⁻¹.

Carbotrap and Carbotrap C graphitized carbon blacks are ideal adsorbents for trapping a wide range of airborne organic compounds (from C₄–C₅ hydrocarbons to polychlorinated biphenyls, polynuclear aromatics and other large molecules). Due to their hydrophobic nature, they enable accurate samples to be obtained, despite a high relative humidity. Because of its higher surface area (100 m² g⁻¹), Carbotrap can be used to trap many C₄–C₈ compounds, while Carbotrap C (10 m² g⁻¹) is preferred for trapping larger airborne organic compounds.

Carbopack B and C are the same adsorbents as Carbotrap and Carbotrap C, respectively, but in the 60–80 mesh size instead of 20–40 mesh. Carbopack graphitized carbon blacks can be used for C₁ to C₁₀ compounds, including alcohols, free acids, amines, ketones, phenols and aliphatic hydrocarbons.

5.1.1.3. Carbon molecular sieves

Carbon molecular sieves are designed for the analysis of permanent gases and light hydrocarbons. For instance, Carbosieve S-III is well suited to the trapping of small airborne molecules such as C₂ hydrocarbons. Carboxen 563 and 564 allow the monitoring of many C₂–C₅ volatile organic compounds (Carboxen 563 having a lower capacity than Carboxen 564); Carboxen 569 has the highest capacity for organic molecules and the lowest capacity for water.

The main features of these sorbents are reported in Table 1 [23].

5.1.2. Porous polymers

The most commonly used porous polymers are reported below; their characteristics are summarized in Table 2 [23].

Table 1

Main characteristics of graphitized carbon blacks and carbon molecular sieves used for preconcentration of trace organic volatiles (from Ref. [23])

Sorbent	Surface area (m ² g ⁻¹)	Temperature limit (°C)
<i>Activated carbon</i>		
Activated coconut charcoal	1070	220
<i>Graphitized carbon blacks</i>		
Carbotrap		
Carbotrap	100	400
Carbotrap C	10	400
Carbopack		
Carbopack B	100	> 400
Carbopack C	10	> 400
Carbopack F	5	
<i>Carbon molecular sieves</i>		
Carbosieve		
Carbosieve G	910	225
Carbosieve S-III	820	400
Carboxen		
Carboxen 563	510	400
Carboxen 564	400	400
Carboxen 569	485	400
Carboxen 1000	1200	400
Carboxen 1004	1100	225

5.1.2.1. Tenax

Tenax GC has been widely used, in spite of its limited specific surface area (19–30 m² g⁻¹), because of its high temperature limit (450°C). This adsorbent is well suited to the collection of high-to-intermediate volatility organic compounds. Thus, it is efficient for C₆–C₁₄ hydrocarbons (at room temperature). Selected monoterpenes could be monitored using this material [24]. It presents the advantage of not retaining water. But it can undergo chemical decomposition in highly oxidizing atmospheres (i.e. in the presence of reactive gases such as O₃ and NO₂), generating benzaldehyde and other oxygenated components which can interfere with the GC determination. Besides, degradation of reactive analytes during sampling may be a serious inconvenient [25].

Tenax TA differs from Tenax GC only in

Table 2
Main characteristics of porous polymers used for preconcentration of trace organic volatiles (from Ref. [23])

Sorbent	Composition	Surface area (m ² g ⁻¹)	Temperature limit (°C)
<i>Tenax</i>			
Tenax GC	Poly (2,6-diphenyl- <i>p</i> -phenylene oxide)	19–30	450
Tenax TA	Poly (2,6-diphenyl- <i>p</i> -phenylene oxide)	35	300
Tenax GR	Poly (2,6-diphenyl- <i>p</i> -phenylene oxide) with 23% graphitized carbon		350
<i>Chromosorb</i>			
Chromosorb 101	Styrene-divinylbenzene copolymer	350	275
Chromosorb 102	Styrene-divinylbenzene copolymer	350	250
Chromosorb 103	Cross-linked polystyrene	350	275
Chromosorb 104	Acrylonitrile-divinylbenzene copolymer	100–200	250
Chromosorb 105	Polyaromatic type	600–700	250
Chromosorb 106	Polystyrene	700–800	225
Chromosorb 107	Polyacrylic ester	400–500	225
Chromosorb 108	Cross-linked acrylic ester	100–200	225
<i>Porapak</i>			
Porapak N	Polyvinylpyrrolidone	225–350	190
Porapak P	Styrene-divinylbenzene copolymer	100–200	250
Porapak Q	Ethylvinylbenzene-divinylbenzene copolymer	500–600	250
Porapak R	Polyvinylpyrrolidone	450–600	250
Porapak S	Polyvinylpyridine	300–450	250
Porapak T	Ethylene glycol dimethyl adipate	250–350	190
<i>HayeSep</i>			
HayeSep A	Divinylbenzene-ethylene glycol dimethacrylate copolymer	526	165
HayeSep D	Divinylbenzene polymer	795	290
HayeSep N	Divinylbenzene-ethylene glycol dimethacrylate copolymer	405	165
HayeSep P	Styrene-divinylbenzene copolymer	165	250
HayeSep Q	Divinylbenzene polymer	582	275
HayeSep R	Divinylbenzene-N-vinyl-2-pyrrolidone copolymer	344	250
HayeSep S	Divinylbenzene-4-vinyl-pyridine copolymer	583	250
<i>Amberlite resins</i>			
XAD-2	Styrene-divinylbenzene copolymer	300	200
XAD-4	Styrene-divinylbenzene copolymer	750	150
XAD-7	Polymethacrylate resin	450	150
XAD-8	Polymethyl-methacrylate resin	140	150

reduced column bleeding [26]. It has very low levels of potentially interfering substances such as aromatic hydrocarbons. It is also suitable for use with highly volatile compounds [27,28]. For example, C₂–C₄ halocarbons [29] and C₆–C₉ hydrocarbons [30] were retained on Tenax TA.

Also, chlordane, an insecticide, was determined in ambient air using sampling tubes packed with Tenax TA [31].

Tenax GR is a recent adsorbent for trapping low-molecular-mass organic solutes. It consists of a Tenax matrix having 23% graphitized carbon.

Sampling volumes are greater than with Tenax GC or Tenax TA (values about twice higher) [32].

5.1.2.2. Chromosorb series

Eight types of Chromosorb porous polymers are commercially available, as indicated in Table 2 (Chromosorb 101–108).

5.1.2.3. Porapak series

In the series, Porapak Q has the highest specific surface area. Several applications of this polymer have been reported [20,33–35].

5.1.2.4. HayeSep series

These are porous polymers. HayeSep N, P, Q, R, S, T are interchangeable with the corresponding Porapak polymers for separating low-molecular-mass mixtures containing halogenated or sulphur-containing compounds, water, alcohols, glycols, free fatty acids, esters, ketones, or aldehydes.

HayeSep A should be used at ambient temperature for permanent gases (hydrogen, nitrogen, oxygen, argon, carbon monoxide, nitric oxide), and at higher temperatures for C₂ hydrocarbons, hydrogen sulphide, or water.

HayeSep D is a new polymer, with a very high purity. Its specific surface area is very large (795 m² g⁻¹) and its maximal operating temperature is high (290°C).

5.1.2.5. Amberlite XAD resins

Amberlite XAD resins are non-ionic macroreticular resins. They adsorb and release species based on hydrophobic or hydrophilic interactions. As with other polymers such as Porapaks and Chromosorbs, only adsorption on the surface occurs.

Amberlite XAD-2 and XAD-4 resins are aromatic in character, very hydrophobic and possess no ion-exchange capacity. For example, Amberlite XAD-4 is particularly effective in adsorbing relatively low-molecular-mass hydrophobic organic compounds.

Amberlite XAD-7 and XAD-8 are acrylic esters resins with a very low ion-exchange capacity. They are more hydrophilic than the

other two resins; as a consequence, they show a higher adsorptive capacity for polar solutes.

Due to their instability on heating, desorption is usually performed by liquid extraction.

5.1.2.6. Polyurethane foam

This sorbent is well suited to the collection of non-volatile analytes using high sampling flow-rates [25]. For example, it was used for the sampling of airborne pesticides and polychlorinated biphenyls [25,36–40]. It is convenient to handle and inexpensive, but exhibits breakthrough of semivolatile and volatile compounds [41].

The choice of the appropriate material is not easy, as it strongly depends on the sample and on the components to be collected. For non-volatile and strongly adsorbed compounds, sample recovery remains the limiting step; on the opposite, very volatile solutes may pass through the sorbent bed without being trapped. Also, the adsorbent must avoid irreproducible results, as well as contamination.

Activated carbon is generally too strong and causes lots of problems; thus, its use should be avoided. Tenax matrices and porous polymers have been successful for a broad range of applications. They have a characteristically low capacity for water, but oxidizing atmospheres should be avoided while working at elevated temperatures. When dealing with very volatile compounds, graphitized carbon blacks or carbon molecular sieves should be preferred, because they show a far better performance than other sorbents such as activated carbon and porous polymers (however they have the drawback of retaining water).

5.2. Sampling mode

5.2.1. Passive sampling (or diffusive sampling)

The tube containing the adsorbent is exposed to the atmosphere, usually in the vertical position; the adsorption process is controlled by the adsorption properties of the sorbent and diffusion processes. This way of sampling is simpler and cheaper than active sampling. In fact, the major disadvantage of this system is that un-

stable flow-rates may be obtained during the sampling period.

Passive samplers are mainly used for the monitoring of workplace atmospheres and the control of industrial areas with potentially very high pollution levels. As an example, they have been used to quantify the exposure of operating room personal to isoflurane, an anaesthetic agent [42]. Sample tubes were packed with different sorbents: Tenax TA, Chromosorb 102 and Chromosorb 106, the latter being the strongest adsorbent in that case. The retained solute was thermally desorbed, preconcentrated in a cool trap, and GC analysed. It was found that Chromosorb 106 was a suitable adsorbent for isoflurane, as it allows a constant sampling rate independent of both time and concentration; no effect of humidity was observed.

In fact, diffusive sampling offers several advantages [43], mainly simplicity, low running costs, and the possibility to make large surveys of air pollution.

However, passive samplers face a major limitation of their use for monitoring trace components in the atmosphere. This is related to the problems of contamination and artefact formation. They are more pronounced than for active samplers because long sampling periods are required with passive samplers, due to the very low uptake rates. Besides, artefacts may form during storage.

To solve these problems, the sampling period needs to be reduced. This could be achieved by using a high-sensitivity detector (a mercuric oxide reduction gas detector) [44]. In this study, passive sampling tubes, packed with different adsorbents (Tenax TA, Tenax GR, Carbotrap or Chromosorb 106), were placed vertically and exposed for about 15 h. They were thermally desorbed and the analytes retrapped cryogenically before their GC analysis. This sensitive detector allowed the determination of VOCs in ambient air, while significantly reducing the sampling periods (8 times lower) compared with those necessary using a flame ionization detector. As an example, Fig. 3 shows representative chromatograms of samples collected onto these adsorbents [44]; concentrations vary from 0.03 ppb to 1 ppb.

5.2.2. Active sampling

Here, a defined volume of air is pumped through the adsorbent at a specific controlled flow-rate.

Care has to be taken to select the correct sorbent, in order to eliminate the risks of breakthrough during sampling as well as artefacts formation. For instance, maximum sample volumes ("breakthrough volumes") of low-molecular-mass compounds were found to be greater on Tenax GR than on Tenax TA or Tenax GC [32]. The breakthrough volumes can be very useful for estimating the amount of adsorbent required to quantitatively trap the solutes of interest for any size air sample.

By selecting sorbents having a large loadability, relatively large air volumes (< 10 l) can be sampled onto the tubes, which enables detection limits as low as 100 ppt. Hence, several adsorbents (including activated charcoals, carbon molecular sieves, porous polymers and graphitized carbons) have been investigated for the trapping of some halocarbons and hydrohalocarbons at ambient temperature [45]. While the activated carbons were too strong adsorbents, the porous polymers appeared to be the less effective for trapping these compounds. In fact, no single adsorbent was suitable. As a consequence, a combination of adsorbents was required. So, a triple-stage trap was designed, containing a porous polymer (HayeSep D) and two carbon molecular sieves (Carboxen 1000 and Carbosieve S-II). Using this system, all of the target analytes were collected from a 5-l air sample at 25°C and efficiently recovered at 200°C [45].

Multiple-packed sorbent tubes are very practical as they afford the opportunity to collect compounds of a wide volatility range. Low-volatility solutes can be retained on a moderate adsorbent, while the more volatile ones go through it; they are subsequently trapped on a stronger adsorbent. This system avoids the irreversible adsorption of low-volatility analytes on the latter sorbent. Several applications have been reported.

Using an organic polymer (Tenax TA) and graphitized carbon black (Carbosphere S), the whole C₂–C₈ fraction of hydrocarbons and

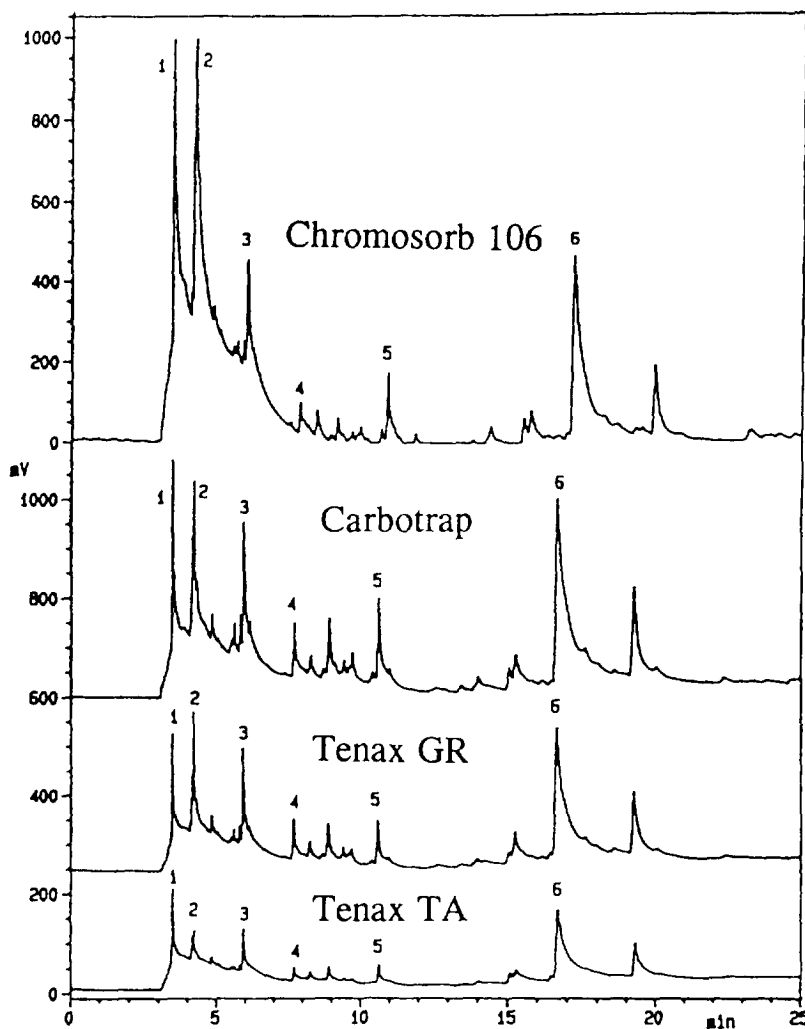

Fig. 3. Chromatograms of passive sampling of VOCs in ambient air (for about 15 h) onto different adsorbents. Peaks: 1 = propylene; 2 = 1-butene; 3 = 1-pentene; 4 = isoprene; 5 = 1-hexene; 6 = benzene. GC conditions: Al_2O_3 -KCl porous-layer open tubular (PLOT) column (50 m \times 0.32 mm I.D.); temperature programme 160°C (8 min), increased at 3°C min^{-1} to 180°C; carrier gas helium; mercuric oxide reduction gas detector. From Ref. [44].

halocarbons in ambient air could be collected [19]. With this combination, low-volatility solutes were adsorbed on the Tenax, while the more volatile ones were subsequently trapped on the Carbosphere S. When only C_2 - C_8 hydrocarbons are of interest, triple-layer cartridges (packed with Tenax TA, Carbotrap and Carbosieve S-III) may be used. With this trapping system, tobacco smoke and vehicle-polluted urban air could be analysed [46].

The combination of carbon adsorbents of

different surface area (Carbotrap C, Carbotrap and Carbosieve S-III) was employed to sample non-polar C_4 - C_{14} hydrocarbons from polluted and unpolluted areas [47]. Carbotrap C (with the smallest surface area: 10 $\text{m}^2 \text{g}^{-1}$) was placed in front to retain high-boiling components and make possible their quantitative recovery without the use of high temperatures during desorption. An ambient relative humidity higher than 50% was found to entail plugging in the system, due to enrichment of water on Carbosieve S-III.

Two-stage traps containing Carbotrap C and Carbotrap particles allowed the monitoring of VOCs in ambient air [48]. A triple-packed adsorbent tube using successively carbon black and molecular sieve sorbents has also been successful for the collection of VOCs in air samples [49].

Chlorophenols could be retained on adsorbent traps containing Tenax GC sandwiched between two polyurethane foam plugs [50].

In addition, adsorbents may be cryogenically cooled during the sampling, to enable the collection of volatile analytes. As an example, -100°C appeared as the optimal trapping temperature of hydrocarbons on Porapak Q [20].

Active sampling is best suited to general environment monitoring. Numerous applications have been reported. Hence, natural VOCs (dimethyl sulphide, bromoform, isoprene and its reaction products) were monitored in the atmosphere by GC-MS, using an adsorption on Tenax TA followed by thermal desorption [51]. An excellent detection limit could be achieved: 1 to 2.4 ppt, with a sampling volume of 0.2 l.

Tenax TA was also investigated as a sorbent for the determination of an insecticide (chlor-dane) [31] and two herbicides (trifluralin and triallate) [52] in air samples.

5.3. Desorption mode

5.3.1. Thermal desorption

Most of the time, thermal desorption (followed by GC) is preferred. Nevertheless, this step is usually too slow for effective capillary GC, so a preconcentration step at the entry of the chromatographic column is required. As a consequence, this results in a two-stage thermal desorption process, as illustrated in Fig. 4 [8]. Most of the time, good resolution has been achieved [53].

When the analytes are too strongly adsorbed (this frequently occurs with polar solutes and strong adsorbents such as activated carbon), thermal desorption is useless to recover the compounds due to the very high temperature needed (too high a value will entail the thermal degradation of the solutes or/and the sorbent bed). In that case, it is very convenient to use liquid extraction.

5.3.2. Liquid extraction

The adsorbent is extracted with a low-boiling solvent (such as carbon disulphide, dichloromethane, benzene or pentane), mostly with Soxhlet-type extraction procedures.

CRYFOFOUSSING

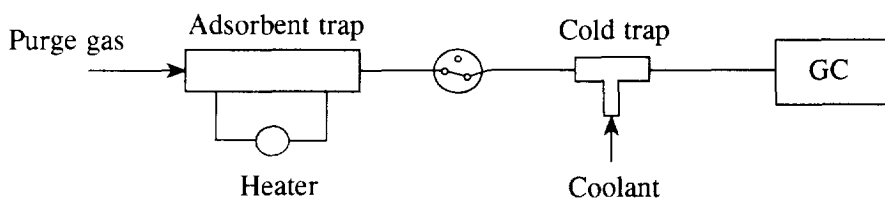

INJECTION

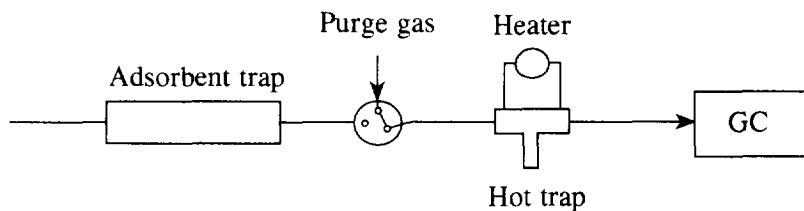

Fig. 4. Schematic representation of the two-stage thermal desorption process following passive or active sampling. From Ref. [8].

Solvent extraction allows longer sorbent beds, as well as higher flow-rates and larger total sample volumes than thermal desorption. Besides, the sample obtained can be analysed using different techniques, leading to more accurate results.

However, trace analysis requires the evaporation of part of the solvent in order to concentrate the analytes. This procedure can lead to several problems: artefacts may be introduced, either by the glassware or by the solvent; losses of volatiles can occur during the evaporation; the solvent peak in the chromatogram can mask the peaks of volatile solutes.

Sorbent tubes offer great flexibility in terms of compatibility with a wide component volatility and polarity range. Recently, automated systems have been developed [54,55]. Nevertheless, collection onto adsorbents presents its own drawbacks also. The sorbent bed may be overloaded, resulting in losses during sampling; interfering compounds may cause problems (like water). Particulates initially present in the sample may clog the system, unless a prefilter is used to remove them. Retained analytes can decompose when using thermal desorption. Finally, a cryofocussing step is required to maintain the resolution during the analysis. An alternative is to use miniaturised traps (also called "microtraps") [56–62].

5.4. Microtraps

A microtrap consists of a small-diameter tubing packed with an adsorbent. Due to their small size (about 5-cm length, with an internal diameter corresponding to the capillary analytical column: 320 to 530 μm), microtraps are well suited to GC. They can be thermally desorbed at the GC flow-rate, which minimises dilution and entails sharp peaks without any cryotrapping or cryofocussing step. Also, they can be extracted with a low volume of solvent, allowing transfer of the whole concentrated sample to the GC.

A very strong adsorbent needs to be chosen, otherwise breakthrough of the analytes will occur. For example, charcoal has been used for the GC analysis of trichloroethylene, tetra-

chloroethylene, benzene and toluene in 20-ml air samples [57]. Detection limits ranged between 0.05 and 3 ng l^{-1} . To retain hydrofluorocarbons (HFCs) and hydrochloro-fluorocarbons (HCFCs), a carbon molecular sieve sorbent (Carboxen) has been used [61].

Breakthrough volumes, desorption temperature and number of theoretical plates have been evaluated for microtraps containing various sorbents (Chromosorb 102, HayeSep D, Graphtrap 5, Charcoal SK4 and Carbosphere) for C_1 and C_2 -halocarbons [58]. Air samples (60 ml) could be analysed by GC with a microtrap packed with HayeSep D at ambient temperature.

In addition, sampling of analytes with wide-range boiling points can be achieved using a composite microtrap, packed with two or more sorbents. Hence, a microtrap containing Carboxen 1003 (6 mg) and Carboxen 1000 (5 mg) allowed the quantitative trapping of the very volatile HFCs and HCFCs at -50°C [59].

Microtraps have a short heating-cooling cycle, which makes them attractive for on-line analysis. For example, continuous monitoring of a gaseous stream containing ppb (v/v) levels of benzene, toluene and xylene could be achieved, using a 6.5-cm long fused-silica microtrap (packed with Carbotrap C) at 22°C [62].

6. Collection onto filters

6.1. Glass-fibre filters (or quartz-fibre filters)

Such filters allow the collection of high-molecular-mass organics associated with air particulates or aerosol particles [63]. Retained analytes can be recovered by Soxhlet extraction, ultrasonic treatment or supercritical fluid extraction.

As an example, more than 140 organic compounds were determined in aeolian particulates from a coastal urban area [64]. These included *n*-alkanes, polycyclic aromatic hydrocarbons (PAHs), *n*-alkanals, 2-alkanones, *n*-alkanols and alkanolic acids. The filter had a collection efficiency higher than 99% for particulates with radius larger than 0.3 μm at $90 \text{ m}^3 \text{ h}^{-1}$. Before

the analysis, acids were first separated by using a LC column containing silica gel, and then the neutral compounds were fractionated by flash chromatography on a silica gel column.

These filters may also be used in conjunction with other trapping materials such as solid sorbents. Hence, a sampling apparatus combined a quartz-fibre filter and two polyurethane foam plugs (PUFPs), as illustrated in Fig. 5 [65]. Ambient air was sampled at $0.6\text{--}0.7\text{ m}^3\text{ min}^{-1}$ for 24 h. The filter and the PUFPs were each extracted with acetone in a Soxhlet extractor. After washing the recovered sample with sulphuric acid and purifying it by silica gel and alumina column chromatography, a GC–MS analysis was performed. This method has been successfully used for monitoring polychlorinated dibenzo-*p*-dioxins (PCDDs) and polychlorinated dibenzofurans (PCDFs) in the atmosphere at ground levels [65].

In another study, a glass-fibre filter followed by a XAD-2 resin was successful in sampling chlorophenols [66].

Also, the collection and quantitation of these analytes in ambient air could be achieved using a

glass-fibre filter followed by a silica gel cartridge, and further GC–MS analysis [67].

Another system was applied to the collection of organotin compounds in air [68]. Air was sampled through two quartz-fibre filters and through an activated carbon-fibre filter at 5 l min^{-1} for 24 h. Each filter was then ultrasonically extracted, and the concentrated solutes analysed using GC.

These filter–sorbent systems have disadvantages. Artefacts may form, due to the adsorption of analytes on the filter or on the collected particles, and to the volatilisation of solutes from particles.

6.2. PTFE filters

These filters have been effective in sampling atmospheric aerosols [69]. Using X-ray fluorescence, the elemental composition of the sample could be determined, while ion chromatography allowed the characterization of the chemical form of the compounds.

6.3. Coated filters

A diffusive sampler has been specially designed for the collection of reactive compounds. It primarily consists of a reagent-coated filter (Fig. 6) [70]. The filter part under the holes is used as a sampling filter, the other half as a blank filter. Once retained on the filters, the solutes were extracted with acetonitrile and analysed by LC.

This sampler has already been validated for formaldehyde with a 2,4-DNPH-coated filter [71], and for diethylamine with a 1-naphthyl isothiocyanate-impregnated filter [72]. Recently, it has also been successfully used for the determination of amines in air (methylamine, isopropylamine, *n*-butylamine, alkylamine and dimethylamine) with the latter reagent [70]. Short-time sampling (30 min) was possible with detection limits below $1\text{ }\mu\text{g l}^{-1}$. The influence of concentration, sampling time and relative humidity on uptake rates was low.

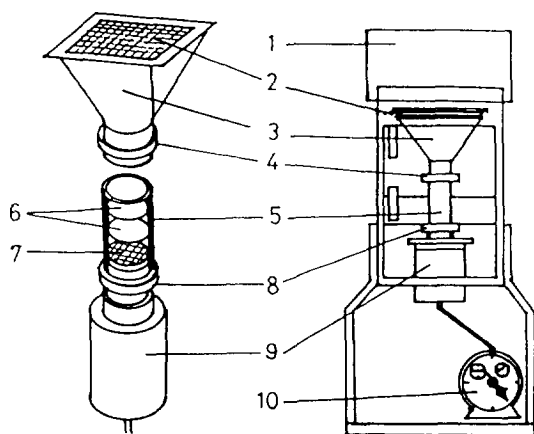

Fig. 5. Design of a sampling apparatus that combines a quartz-fibre filter and two polyurethane foam plugs (PUFPs): 1 = shelter; 2 = filter and stainless-steel wire net; 3 = filter holder; 4 = screw clasp with PTFE packing; 5 = PUF holder; 6 = two PUF plugs; 7 = stainless-steel wire net; 8 = screw clasp with PTFE packing; 9 = high-volume air-suction pump; 10 = integrating gas flow-meter. From Ref. [65].

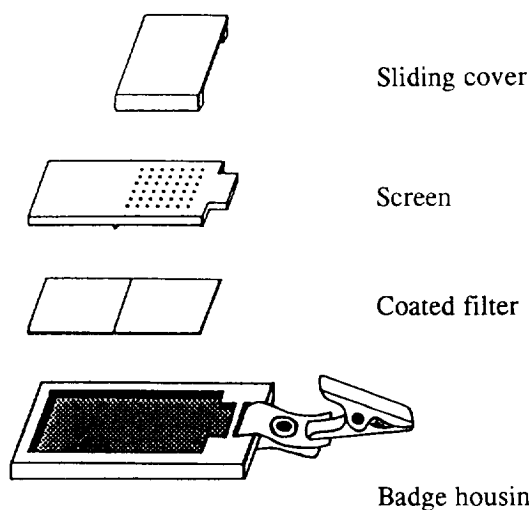

Fig. 6. Diffusive sampler for the collection of reactive compounds. From Ref. [70].

7. Collection onto fibres

7.1. Solid-phase microextraction

Solid-phase microextraction (SPME) is a very useful technique for air sampling. It is portable, inexpensive, requires no solvent, and can be used with any type of gas chromatograph.

The SPME device, illustrated in Fig. 7 [73], is easy to transport: a fused-silica fibre coated with

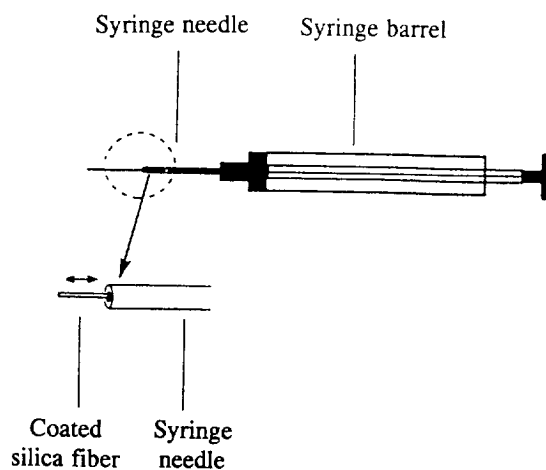

Fig. 7. Solid-phase microextraction device. From Ref. [73].

a polymeric organic liquid is contained in a syringe. The fibre is placed in the atmosphere and the analytes partition into it. Once equilibrium has been reached, the fibre containing the concentrated solutes is transferred to the injector of a GC, where the compounds are thermally desorbed (they may be cryofocussed at the head of the chromatographic column during the desorption, because the desorption time can be longer than the elution time of a chromatographic band in a capillary column).

This technique has been used to determine volatile chlorinated organic compounds in air [73]. Samples were taken by exposing the fibre for 35–45 min.

7.2. Membrane extraction with a sorbent interface

A new analytical method has been recently reported [74]. It combines membrane extraction, cryofocussing and thermal desorption. Fig. 8 shows the schematic representation of the system; the membrane probe consists of a hollow silicone fibre. Extracted compounds were indeed cryogenically focused at the head of the capillary column. After a certain time, an electrical pulse was applied to thermally desorb the solutes into the carrier gas stream for GC analysis.

Membrane extraction with a sorbent interface (MESI) has been used as a simple and effective VOCs monitoring station [74]. Unlike the common methods for air sampling, it eliminates the

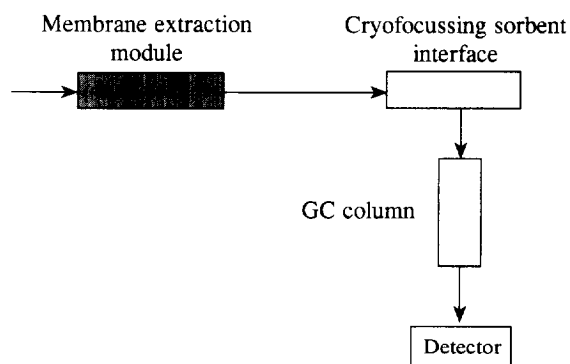

Fig. 8. Schematic representation of the membrane extraction with a sorbent interface system. From Ref. [74].

need for a sorbent cartridge, organic solvents, and a drying step.

8. Conclusions

Numerous preconcentration procedures now exist. However, collection on adsorbents has probably become one of the most popular methods, and it is often proposed as a method of choice by official organisations. Most of the time, volatile organic compounds are transferred from the sorbent tube to the analytical column using rapid thermal desorption; in some cases, a cryofocussing step may be required if insufficient resolution is obtained.

The development of microtraps should allow the continuous monitoring of air pollution, once the sorbent has been correctly chosen.

Nevertheless, the choice of the adsorbent nature is very difficult and often two or three types of adsorbents must be used in series to collect a broad range of solutes.

A recent technique, solid-phase microextraction, is also very promising. It offers many advantages over the other methods: easy to transport, low cost, no solvent needed. Therefore, it should face a growing interest in the next few years.

References

- [1] A. Yasuhara and T. Shibamoto, *J. Chromatogr. A*, 672 (1994) 261–266.
- [2] J. Rudolph, K.P. Müller and R. Koppmann, *Anal. Chim. Acta*, 236 (1990) 197–211.
- [3] J.P. Hsu, G. Müller and V. Moran, *J. Chromatogr. Sci.*, 29 (1991) 83–88.
- [4] G.F. Evans, T.A. Lumplein, D.L. Smith and M.C. Somerville, *J. Air Waste Manage. Assoc.*, 42 (1992) 1319–1323.
- [5] E.A. Woolfenden and G.M. Broadway, *LC–GC Intl.*, 5 (12) (1992) 28–35.
- [6] S. Müller and M. Oehme, *J. High Resolut. Chromatogr.*, 13 (1990) 34–39.
- [7] J.Y.K. Lai, E. Matisova, D. He, E. Singer and H. Niki, *J. Chromatogr.*, 643 (1993) 77–90.
- [8] C.L.P. Thomas, *Eur. Chromatogr. Anal.*, April/May (1991) 5–7.
- [9] S.K. Poole, T.A. Dean, J.W. Oudsema and C.F. Poole, *Anal. Chim. Acta*, 236 (1990) 3–42.
- [10] A.H.J. Grömping and K. Cammann, *Chromatographia*, 35 (1993) 142–148.
- [11] A.H.J. Grömping, U. Karst and K. Cammann, *J. Chromatogr. A*, 653 (1993) 341–347.
- [12] E. Cohen and N. Rizov, *Chromatographia*, 37 (1993) 105–106.
- [13] A.C. Geng, Z.L. Chen and G.G. Siu, *Anal. Chim. Acta*, 257 (1992) 99–104.
- [14] Z. Zdrahal and Z. Vecera, *J. Chromatogr. A*, 668 (1994) 371–374.
- [15] S. Zaromb, J. Alcaraz, D. Lawson and C.S. Woo, *J. Chromatogr.*, 643 (1993) 107–115.
- [16] M. Possanzini, P. Ciccio, V. Di Palo and R. Draisci, *Chromatographia*, 23 (1987) 829.
- [17] R. Simo, J.O. Grimalt and J. Albaiges, *J. Chromatogr. A*, 655 (1993) 301–307.
- [18] N. Schmidbauer and M. Oehme, *J. High Resolut. Chromatogr.*, 8 (1985) 404–406.
- [19] F.J. Reinecke and K. Bächmann, *J. Chromatogr.*, 323 (1985) 323–329.
- [20] T. Noy, P. Fabian, R. Borchers, F. Janssen, C. Cramers and J. Rijks, *J. Chromatogr.*, 393 (1987) 343–356.
- [21] W. Thain, *Monitoring Toxic Gases in the Atmosphere for Hygiene and Pollution Control*, Pergamon Press, New York, NY, 1980, p. 64.
- [22] F. Bruner, G. Crescentini and F. Mangani, *Chromatographia*, 30 (1990) 565–572.
- [23] A.J. Nunez, L.F. Gonzalez and J. Janak, *J. Chromatogr.*, 300 (1984) 127–162.
- [24] V.A. Isidorov, I.G. Zenkevich and B.V. Joffe, *Atmos. Environ.*, 19 (1985) 1.
- [25] M.P. Ligocki and J.F. Pankow, *Anal. Chem.*, 57 (1985) 1138–1144.
- [26] G. MacLeod and J. Ames, *J. Chromatogr.*, 355 (1986) 393–398.
- [27] E. Tsani-Bazaca, A.E. McIntyre, J.N. Lester and R. Perry, *Environ. Technol. Lett.*, 2 (1981) 303.
- [28] I. Maier and M. Fieber, *J. High Resolut. Chromatogr.*, 11 (1988) 566–576.
- [29] Th. Class and K. Ballschmiter, *J. Atmos. Chem.*, 6 (1988) 35.
- [30] R.S. Hutte, E.J. Williams, J. Staehelin, S.B. Hawthorne, R.M. Barkeley and R.E. Sievers, *J. Chromatogr.*, 302 (1984) 173.
- [31] T. Yamashita, K. Haraguchi, A. Kido and H. Matushita, *J. Chromatogr. A*, 657 (1993) 405–411.
- [32] K. Ventura, M. Dostal and J. Churacek, *J. Chromatogr.*, 642 (1993) 379–382.
- [33] J. Rudolf, F.J. Johnen, A. Khedin and G. Pilwat, *Int. J. Environ. Anal. Chem.*, 38 (1990) 43.
- [34] P.V. Doskey, *J. High Resolut. Chromatogr.*, 14 (1991) 724.
- [35] H.J. Schaeffer, *J. High Resolut. Chromatogr.*, 12 (1989) 69.
- [36] F.R. Guenther, S.N. Chesler, G.E. Gordon and W.H. Zoller, *J. High Resolut. Chromatogr. Chromatogr. Commun.*, 11 (1988) 761.

- [37] G.J. Moody and J.D.R. Thomas, *Chromatographic Separation and Extraction with Foamed Plastic and Rubbers*, Dekker, New York, NY, 1982.
- [38] B.C. Turner and D.E. Glotfelty, *Anal. Chem.*, 49 (1977) 7.
- [39] B.C. Turner, D.E. Glotfelty, A.W. Taylor and D.R. Watson, *Agron. J.*, 70 (1978) 933.
- [40] M.M. Cliath, W.F. Spencer, W.J. Farmer, T.D. Shoup and R. Grover, *J. Agric. Food Chem.*, 13 (1980) 610.
- [41] W.N. Billings and T.F. Bidleman, *Environ. Sci. Technol.*, 14 (1980) 679.
- [42] C. Prado, F. Periago, I. Ibane and J. Tortosa, *J. Chromatogr. A*, 657 (1993) 131–137.
- [43] X.-L. Cao and C.N. Hewitt, *Environ. Technol.*, 12 (1991) 1055–1062.
- [44] X.-L. Cao and C.N. Hewitt, *J. Chromatogr.*, 648 (1993) 191–197.
- [45] W.T. Sturges and J.W. Elkins, *J. Chromatogr.*, 642 (1993) 123–134.
- [46] G. Barrefors and G. Petersson, *J. Chromatogr.*, 643 (1993) 71–76.
- [47] P. Ciccioli, A. Cecinato, E. Brancaleoni, M. Frattoni and A. Liberti, *J. High Resolut. Chromatogr.*, 15 (1992) 75.
- [48] P. Ciccioli, E. Brancaleoni, A. Cecinato, R. Sparapani and M. Frattoni, *J. Chromatogr.*, 643 (1993) 55–69.
- [49] A.P. Bianchi and M.S. Varney, *J. Chromatogr.*, 643 (1992) 11–23.
- [50] G.W. Patton, L.L. Mc Connell, M.T. Zaranski and T.F. Bidleman, *Anal. Chem.*, 64 (1992) 2858–2861.
- [51] Y. Yokouchi, H. Bandow and H. Akimoto, *J. Chromatogr.*, 642 (1993) 401–407.
- [52] A.J. Cessna and L.A. Keu, *J. Chromatogr.*, 642 (1993) 417–423.
- [53] P. Matsuka, M. Koval and W. Seiler, *J. High Resolut. Chromatogr.*, 9 (1986) 577–583.
- [54] N. Kirshen and E. Almasi, *J. High Resolut. Chromatogr.*, 14 (1991) 484–489.
- [55] T. Kohno and K. Kuwata, *J. Chromatogr.*, 587 (1991) 338–342.
- [56] M. Fujita, W.T. Jung, H. Tatematu, D.H. Sohn and T. Maeda, *J. High Resolut. Chromatogr.*, 14 (1991) 83.
- [57] K. Grob, A. Artho, C. Frauenfelder and I. Roth, *J. High Resolut. Chromatogr.*, 13 (1990) 257–260.
- [58] W. Frank and H. Frank, *Chromatographia*, 29 (1990) 571–574.
- [59] S.J. O'Doherty, P.G. Simmonds and G. Nickless, *J. Chromatogr. A*, 657 (1993) 123–129.
- [60] H. Frank, W. Frank, H.J.C. Neves and R. Englert, *Fresenius' J. Anal. Chem.*, 340 (1991) 678–683.
- [61] S.J. O'Doherty, P.G. Simmonds, G. Nickless and W.R. Betz, *J. Chromatogr.*, 630 (1993) 265–274.
- [62] S. Mitra and C. Yarn, *J. Chromatogr.*, 648 (1993) 415–421.
- [63] P. Sandra, *Analisis*, 20 (1992) m32–m35.
- [64] E.G. Stephanou and N.E. Stratigakis, *J. Chromatogr.*, 644 (1993) 141–151.
- [65] K. Kuwata, Y. Yamashita, S. Nakashima, Y. Nakato, T. Kohno, S. Tanaka, T. Okunura and Y. Yamaguchi, *J. Chromatogr.*, 643 (1993) 25–33.
- [66] H. Kontsas, C. Rosenberg, P. Jäppinen and M.L. Riekkola, *J. Chromatogr.*, 636 (1993) 255–261.
- [67] R.M. Smith, P.W. O'Keefe, D.R. Hilker and K.M. Aldous, *Anal. Chem.*, 58 (1986) 2414–2420.
- [68] K. Kawata, M. Minagawa, Y. Fujieda and A. Yasuhara, *J. Chromatogr. A*, 653 (1993) 369–373.
- [69] E. Dabek-Zlotorzynska and J.F. Dlouhy, *J. Chromatogr.*, 640 (1993) 217–226.
- [70] R. Lindahl, J.-O. Levin and K. Andersson, *J. Chromatogr.*, 643 (1993) 35–41.
- [71] J.-O. Levin, R. Lindall and K. Andersson, *Environ. Technol. Lett.*, 9 (1988) 1423–1430.
- [72] J.-O. Levin, R. Lindall, K. Andersson and C. Hallgen, *Chemosphere*, 18 (1989) 2121–2129.
- [73] M. Chai, C.L. Arthur, J. Pawliszyn, R.P. Belardi and K.F. Pratt, *Analyst*, 118 (1993) 1501–1505.
- [74] M.J. Yang, S. Harms, Y.Z. Luo and J. Pawliszyn, *Anal. Chem.*, 66 (1994) 1339–1346.